



SOUTHERN CALIFORNIA HYDRAULIC ENGINEERING CORPORATION

Designer and Manufacturers of Hydraulic & Pneumatic Equipment

1130 COLUMBIA STREET, BREA, CALIFORNIA 92821 - WWW.SCHYDRAULIC.COM

10-6 SERIES PUMP: "LUBE" AND "NON-LUBE" AIR MOTOR ASSEMBLIES, BUNA.

DOC. NO. D15138, REV. A, 09-10-2019, M.E.
PAGE 1 OF 4

"LUBE" AIR MOTOR ASSEMBLY 11-6094A000 "NON-LUBE" AIR MOTOR ASSEMBLY 11-6094ADL0 (P/N 11-6094ADL0 WAS C10515)

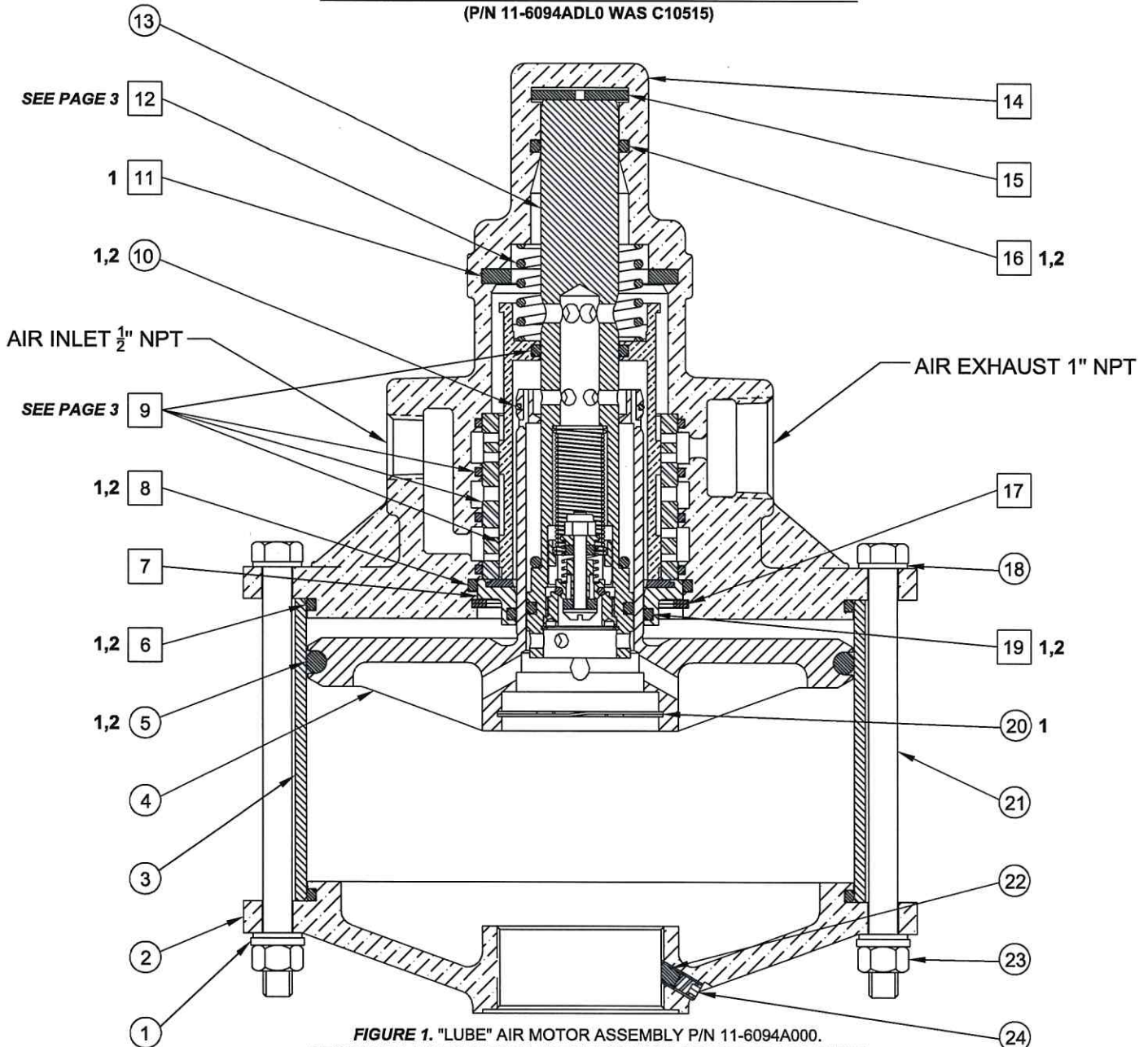

FIGURE 1. "LUBE" AIR MOTOR ASSEMBLY P/N 11-6094A000.
SEE PAGE 2 & 3 FOR "NON-LUBE" (DRY LUBE) AIR MOTOR ASSEMBLY
P/N 11-6094ADL0 AND C10515.

NOTES: "LUBE" AIR MOTOR ASSEMBLY 11-6094A000.

1. INCLUDED IN 11-6100N000 AIR MOTOR REPAIR KIT.
2. INCLUDED IN 11-6130N000 AIR MOTOR PACKING SET.
3. REQUIRES LUBRICATOR INSTALLED IN DRIVE-AIR LINE.

INCLUDED IN 11-6128A000 HEAD ASSEMBLY.

NOTES: "NON-LUBE" AIR MOTOR ASSEMBLY 11-6094ADL0.

1. INCLUDED IN 11-6100NDL0 AIR MOTOR REPAIR KIT.
2. INCLUDED IN 11-6130NDL0 AIR MOTOR PACKING SET.
3. P/N 11-6094ADL0 WAS C10515.
4. P/N 11-6100NDL0 WAS R10104.
5. P/N 11-6130NDL0 WAS R10105.
6. DOES NOT REQUIRE LUBRICATOR INSTALLED IN DRIVE-AIR LINE.

INCLUDED IN C10516 HEAD ASSEMBLY.



SOUTHERN CALIFORNIA HYDRAULIC ENGINEERING CORPORATION
Designer and Manufacturers of Hydraulic & Pneumatic Equipment

1130 COLUMBIA STREET, BREA, CALIFORNIA 92821 - (714) 257-4800 - FAX (714) 257-4810

10-6 SERIES PUMP: "LUBE" AND "NON-LUBE" AIR MOTOR ASSEMBLIES, BUNA.

A. "LUBE" AIR MOTOR ASSEMBLY P/N 11-6094A000 (REFER TO ITEM 9A & 12A).

B. "NON-LUBE" (DRY LUBE) AIR MOTOR ASSEMBLY P/N 11-6094ADL0 (REFER TO ITEM 9B & 12B).

DOC. NO. D15138, REV. A, 09-10-2019, M.E.

PAGE 2 OF 4

ITEM NO	QTY	PART NO	DESCRIPTION	REFERENCE NO
1	8	P10212-038	LOCK WASHER	----
2	1	11-6002A000	END	10-550-2
3	1	11-6151P000	AIR CYLINDER	10-550-151
4	1	11-6025A000	AIR PISTON	10-550-25
5	1	P11000-439	O-RING	12-6227N066
6	2	P11000-261	O-RING	12-6230N039
7	1	11-5047N000	BEARING ASSEMBLY	10-450-47
8	1	P11000-231	O-RING	12-6230N009
9A *	1	11-6152A000	"LUBE" APA VALVE ASSEMBLY. (SEE PAGE 3)	10-550-152
9B *	1	11-6152ADL0	"NON-LUBE" (DRY-LUBE) APA VALVE ASSEMBLY. (SEE PAGE 3)	10-550-152DL
10	1	P11000-028	O-RING	12-8775N028
11	1	11-5057P000	BUMPER	10-450-57
12A *	1	11-5005M001	SPRING, RETURN (USE WITH ITEM No. 9A, SEE PAGE 3)	10-450-5-1
12B *	1	11-5005M002	SPRING, RETURN (USE WITH ITEM No. 9B, SEE PAGE 3)	10-450-5-2
13	1	11-6027A000	PILOT VALVE ASSEMBLY	10-550-27
14	1	11-6092A000	HEAD	10-550-92
15	1	11-5012N000	BUMPER	10-450-12
16	1	P11000-214	O-RING	12-6227N019
17	1	12-R262S000	RETAINING RING	RRT-262
18	16	P10214-038	FLAT WASHER	----
19	1	P11000-223	O-RING	12-6230N001
20	1	12-R200S000	RETAINING RING	RRT-200
21	8	P10230	HEX BOLT	----
22	1	11-5172N000	PLUG	10-450-172
23	8	12-37CNFH1Z	HEX NUT	----
24	1	P10238	HEX-SOCKET SET-SCREW	12-25C313CPSS

*** ITEM 9A: "LUBE" APA VALVE ASSEMBLY.**

P/N 11-6152A000.
 SEE PAGE 3 FOR DETAILS.

ITEM NO	QTY	PART NO	DESCRIPTION	REFERENCE NO
9A.1	1	P11000-214	O-RING	12-6227N019
9A.2	1	11-6153A000	PISTON, APA	10-550-153
9A.3	1	11-6126A000	SLEEVE, APA	10-550-126
9A.4	4	P11000-144	O-RING	12-8775N144

*** ITEM 9B: "NON-LUBE" (DRY LUBE) APA VALVE ASSEMBLY.**

P/N 11-6152ADL0.
 SEE PAGE 3 FOR DETAILS.

ITEM NO	QTY	PART NO	DESCRIPTION	REFERENCE NO
9B.1	1	P11000-214	O-RING	12-6227N019
9B.2	1	P10263-193	RETAINING RING	----
9B.3	1	D10684	SEAL, DRY LUBE	----
9B.4	1	P11000-135	O-RING	12-8775N135
9B.5	1	D10817	PISTON, APA	----
9B.6	2	P11003-137	O-RING	----
9B.7	1	D10263	SLEEVE, APA	----
9B.8	4	P11000-144	O-RING	12-8775N144



SOUTHERN CALIFORNIA HYDRAULIC ENGINEERING CORPORATION
Designer and Manufacturers of Hydraulic & Pneumatic Equipment

1130 COLUMBIA STREET, BREA, CALIFORNIA 92821 - (714) 257-4800 - FAX (714) 257-4810

BILL OF MATERIALS FILE: 10550169.XLS

DRAWING NUMBER & DESCRIPTION: 11-6169S000-HF4 (740:1) HYDRAULIC ASSEMBLY

REVISION: 05/17/06

ITEM NO	QTY	PART NO	DESCRIPTION	REFERENCE NO
1	2	11-6016S000	SPRING	10-550-16
2	2	P11000-010	O-RING	12-6227N005
3	2	12-0440S250	CHECK BALL	
4	1	11-6136S000	SEAT-INLET	10-550-136
5	2	11-6015S000	BALL GUIDE	10-550-15
6	1	11-6160B400	BEARING-LOWER	10-550-160-40
7	1	11-5028N000	GASKET	10-450-28
8	1	P11202-007	SEAL-ROD	
9	1	D10653-6P	BACK UP PEEK	
10	1	11-6163B400	BEARING-UPPER	10-550-163
11	1	P10212-025	HELICAL SPRING LOCK WASHER	12-5001C407
12	1	12-25F37SBC45Z	BUTTON HEAD CAP SCREW	
13	1	12-25N87WF1Z	FENDER WASHER	
14	1	11-5051P000	PISTON BUMPER	10-450-51
15	1	11-6162S400	RETAINER	10-550-162-40
16	1	11-6008S400	HYDRAULIC PISTON	10-550-8-40
17	1	11-6157S402	HYDRAULIC CYLINDER	10-550-157-40-2
18	1	11-6134S000	SEAT-OUTLET	10-550-134
19	1	11-6135S000	ADAPTER	10-550-135

Where Used 10-600KS402-HF4
Pump Assemblies 10-6000S402-HF4
 D6000AS740-HF4